

# Pressure Control Valves

## Sliding Gate Valves UV 6.7, 6.8



High-efficiency Backpressure Regulator

### Technical Data

Connection DN	15 - 150
Nominal Pressure PN	10 - 40
Inlet Pressure	0.1 - 10 bar
K <sub>vs</sub> -Value	4 - 338 m <sup>3</sup> /h
Temperature	300 °C
Medium	liquids, gases and steam

### Description

Medium-controlled overflow valves are simple control valves offering accurate control while being easy to install and maintain. They control the pressure upstream of the valve without requiring pneumatic or electrical control elements.

The UV 6.7 and UV 6.8 overflow valves are spring-loaded proportional control valves for large volumes providing the following special features:

- space-saving installation between flanges
- low weight (especially for the large valve sizes)
- valve body geometry common to all pressure ranges PN 10-40
- high K<sub>vs</sub> ratings
- low leakage
- low-noise operation

Two slotted discs which slide and seal against each other are operated by a medium-controlled spring-loaded diaphragm drive mechanism. When the system is depressurised the valve spring keeps the valve closed. As the inlet pressure rises it acts on the diaphragm/spring mechanism via the pilot line. The inlet pressure to be controlled is balanced across the diaphragm by the force of the valve spring (set pressure). As the inlet pressure rises above the pressure set using the adjusting screw, the slot width increases. The resulting volume will be such that the inlet pressure to be controlled (set pressure) is kept constant within the limits of the proportional control error. Rotating the adjusting screw clockwise increases the inlet pressure.

For steam applications (up to 300 °C) the diaphragm control unit must be filled with water via the pilot line connection before the valve is commissioned.

### Options

- » for toxic or hazardous media: sealed bonnet complete with leakage line connection (incl. sealed adjusting screw). Must be installed with a leakage line capable of draining leaking medium safely and without pressure
- » various diaphragm and seal materials suitable for your medium
- » special versions on request

Operating instructions, know how and safety instructions must be observed. All the pressure has always been indicated as overpressure. We reserve the right to alter technical specifications without notice.



#### K<sub>vs</sub>-Values [m<sup>3</sup>/h] and max. Δp [bar]

nom. diam. DN	15	20	25	32	40	50
K <sub>vs</sub> -value m <sup>3</sup> /h	4	6.4	11	16	26	45
max. Δp bar	10	10	10	10	10	10

#### K<sub>vs</sub>-Values [m<sup>3</sup>/h] and max. Δp [bar]

nom. diam. DN	65	80	100	125	150
K <sub>vs</sub> -value m <sup>3</sup> /h	52	92	154	237	338
max. Δp bar	10	6	3.8	2.4	1.9

#### Setting Range [bar], Nominal Pressure PN

0.1 - 0.15	0.1 - 0.3	0.2 - 0.6	0.5 - 1.2	1 - 2.5	2 - 5	4 - 10
PN 1	PN 1	PN 1	PN 2.5	PN 6	PN 10	PN 16

# Pressure Control Valves

## Sliding Gate Valves UV 6.7, 6.8



High-efficiency Backpressure Regulator

Materials			
Design	standard	medium wetted CrNiMo-st	completely CrNiMo-st
Body	C-steel	CrNiMo-steel	CrNiMo-steel
Diaphragm Housing	C-steel	CrNiMo-steel	CrNiMo-steel
Bonnet	C-steel	C-steel	CrNiMo-steel
Spring	spring steel C	spring steel C	CrNi-steel
Plates (valve seal)	CrNiMo-steel/ special carbon material, metallic impregnation		
Diaphragm	CR optional FPM, EPDM or PTFE		

Dimensions [mm]												
setting range bar	size	nominal diameter DN										
		15	20	25	32	40	50	65	80	100	125	150
all ranges	A	33	33	33	33	33	43	46	46	52	56	56
	E	53	62	72	82	92	108	127	142	164	194	219
0.1 - 0.3	B*	550	555	560	680	685	695	705	715	725	740	755
	D	360	360	360	500	500	500	500	500	500	500	500
0.2 - 0.6	B*	550	555	560	680	685	695	705	715	725	740	755
	D	270	270	270	360	360	360	360	360	360	360	360
0.5 - 1.2	B*	550	555	560	680	685	695	705	715	725	740	755
	D	220	220	220	270	270	270	270	270	270	270	270
1.0 - 2.5 / 2-5 / 4-10	B*	530	535	540	680	685	695	705	715	725	740	755
	D	175	175	175	220	220	220	220	220	220	220	220

\*max. size with stressless spring  
type 6.8 (closed spring cap) size C + 200 mm

Weights [kg]											
setting range bar	nominal diameter DN										
	15	20	25	32	40	50	65	80	100	125	150
0.1 - 0.3	19.7	19.8	19.9	23	23.1	24.2	24.7	25.4	25.6	28.4	30.4
0.2 - 0.6	16.7	16.8	16.9	22	22.1	23.2	23.7	24.4	24.6	27.4	29.4
0.5 - 1.2	23.7	23.8	13.9	19	19.1	20.2	20.7	21.4	22.6	24.4	26.4
1.0 - 10	12.7	12.8	12.9	16	16.1	17.2	17.7	18.4	19.6	21.4	23.4

Special designs on request.  
The pressure has always been indicated as overpressure.  
Mankenberg reserves the right to alter or improve the designs or specifications of the products described herein without notice.

### Dimensional Drawing

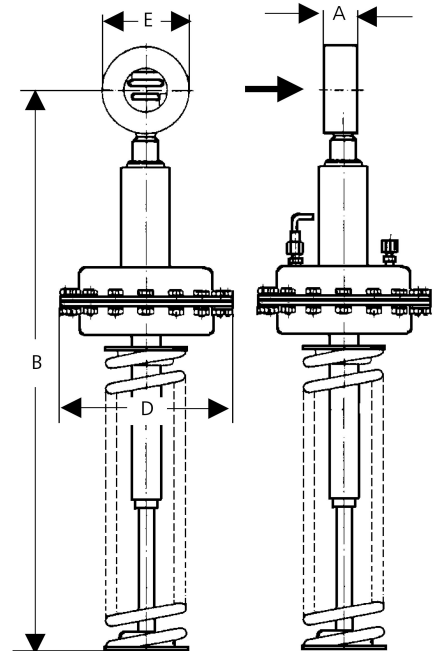

D = diaphragm  $\varnothing$   
sense line  $\varnothing$  8/6 mm Ermeto

### Recommended Installation

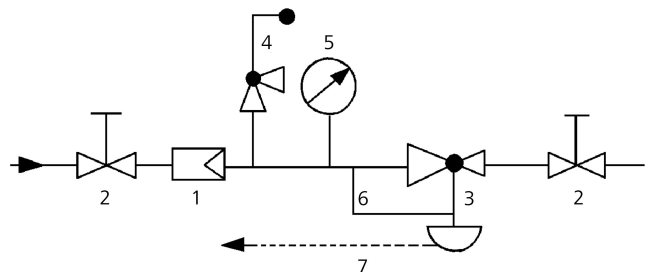

- 1 Strainer
  - 2 Shut-off Valves
  - 3 Overflow Valve
  - 4 Safety Valves
  - 5 Pressure Gauge
  - 6 Sense Line tube  $\varnothing$  8/6
  - 7 Leakage Line (option)
- sense line connection 10 - 20 x DN before the valve.  
use MANKENBERG-Products