

Pressure Control Valves



Pressure Reducing Valves DM 762

Your advantages at a glance

Connection	DN 15 - 50, G 1/2 - 2
Nominal Pressure	PN 16
Inlet Pressure	up to 16 bar
Outlet Pressure	0,002 - 0,52 bar
K _{V5} Value	0,2 - 3,6 m ³ /h
Temperature	130°C
Medium	liquids, gases

Millibar Control Valve

millibar control valve for medium flow rates, very precise, available in various versions | suitable for liquids and gases | completely made of deep-drawn CrNiMo steel | optimal surface characteristics, highest regulating accuracy, lowest control ranges up to a limit of 2 millibar

www.mankenberberg.de | Tel. +49 (0) 451 - 8 79 75 0

MANKENBERG GmbH | Spenglerstraße 99 | D-23556 Lübeck

Sheet no. DM 762/6.1.111.1 issue 14.11.2011

compact, pressure-resistant, corrosion-resistant by deep drawn 316 Stainless steel

long operational lifespan, easy installation, minimum space required, possibly low content of delta-ferrite

various connection alternatives: Aseptic-, DIN- or ANSI flanges welded ends

no adapters or fitting pieces required

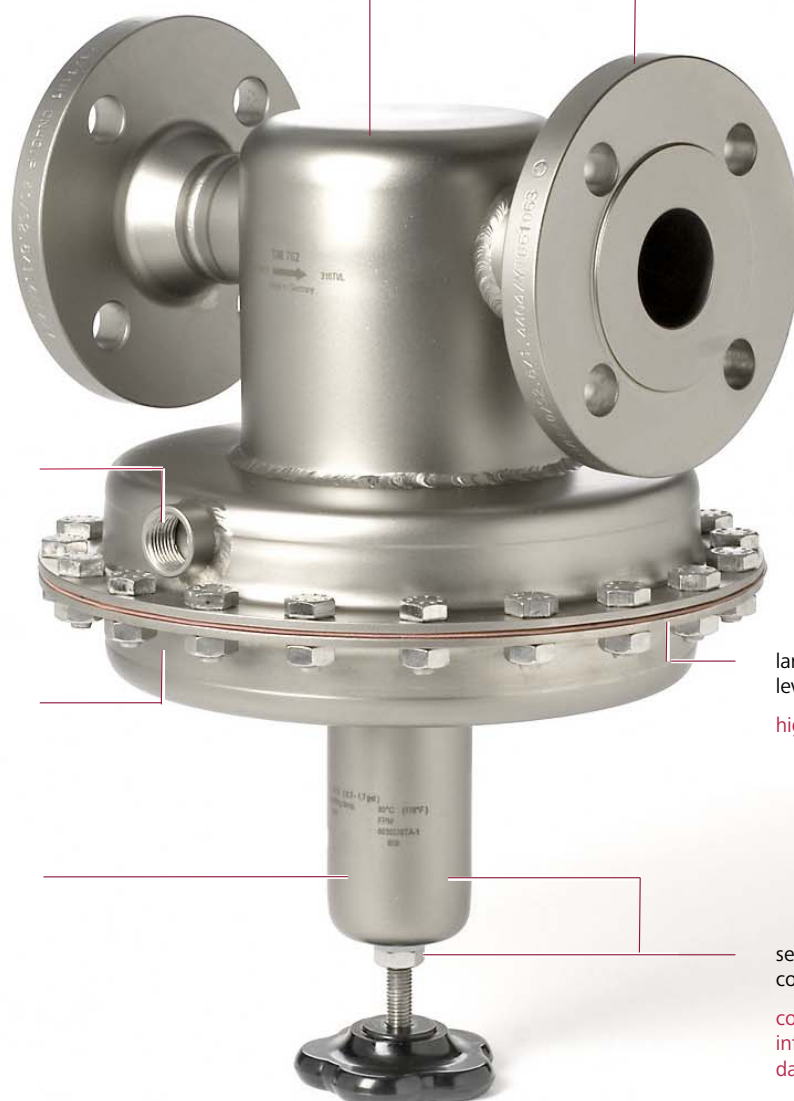

sense line connection
minimum control deviation

many control modules available
most accurate regulation

standard surface < RA 1,6 µm
easy to clean

large control surface, elaborate lever mechanic
high reduction ratios possible

sealed bonnet with leakage line connection (option)
compliant with UVV, suitable for inflammable and dangerous media